

ISS.	AMEND	DATE
1	1st DRAWN	05/04/94
2	TEETH CHANGE	28/06/94
3	PCB: 4mm WAS 5mm	30/06/94
4	16 TEETH WAS 20	06/07/94
5	Ø11.0 WAS Ø10.8	14/07/94
6	SEE MOD 0214	12/08/96
7	WAS CL14422	07/04/06
8	UPDATED	11/06/06
9	Ø11.2 WAS Ø11 REDRAWN	12/07/11

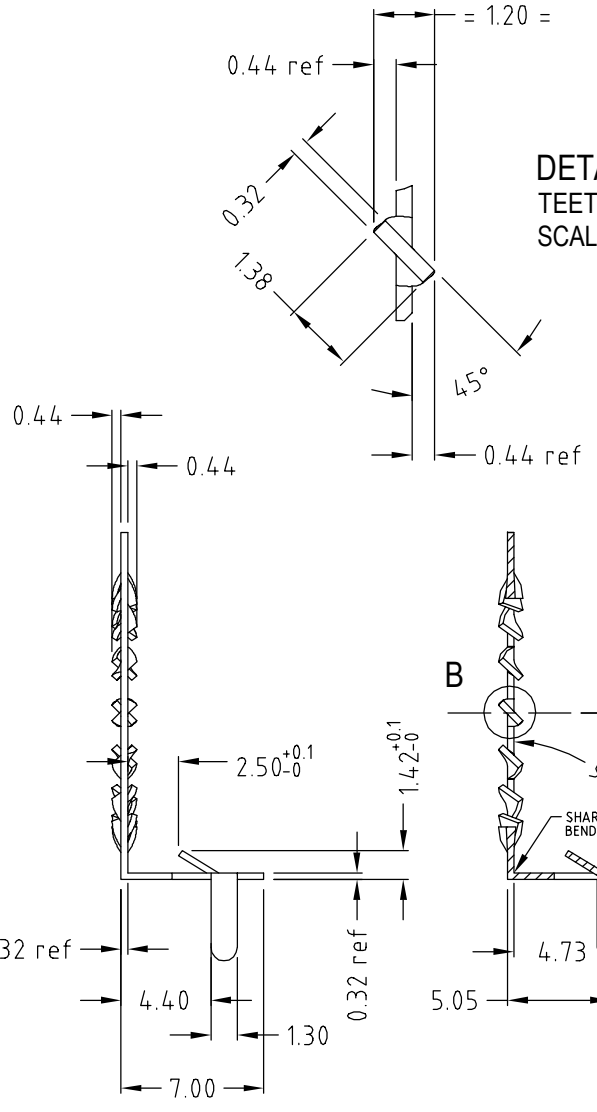

**DETAIL B**  
TEETH TWISTED 45°  
SCALE 2.5 / 1

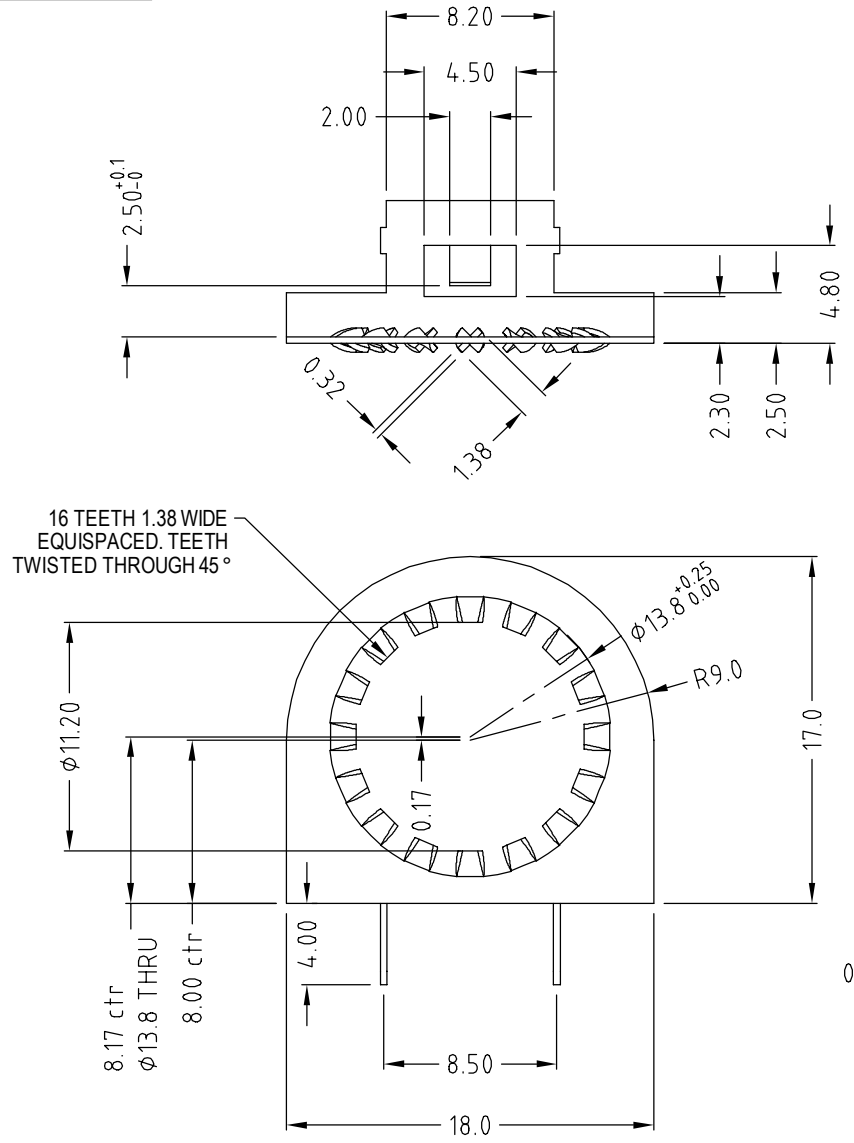
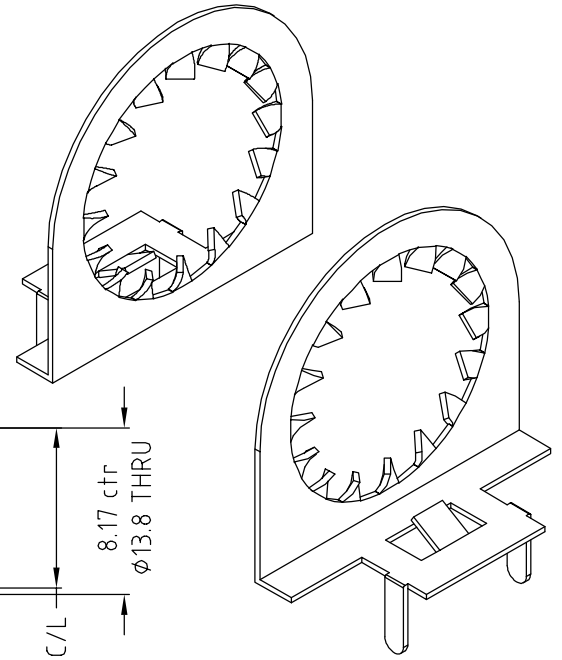

<b>RoHS</b> COMPLIANT
<b>TOLERANCE</b>
NO DEC. PLACE ± 0.25
1 DEC. PLACE ± 0.10
2 DEC. PLACE ±
HOLE Ø ±
ANGLES ± 1/2°
UNLESS OTHERWISE STATED
DO NOT SCALE

**Cliff Electronic Components Ltd.**  
76 Holmesthorpe Avenue, Holmesthorpe Industrial Estate,  
Redhill, Surrey, RH1 2PF, England, UK  
Tel: 01737-771375 Fax: 01737-766012 Website: www.cliffuk.co.uk

DIMENSIONS IN MILLIMETERS UNLESS OTHERWISE STATED. WORK TO DIMENSIONS. REMOVE ALL BURRS. IF IN DOUBT ASK.

3rd ANGLE PROJECTION:

MATERIAL: SPRING STEEL 0.32mm THK

TITLE: EARTHING WASHER FOR S2/S4 J/SKT (2 PIN TYPE)

FINISH: TIN PLATED (MUST BE SOLDERABLE)

THE CONTENTS OF THIS DOCUMENT MUST NOT BE COPIED OR DISCLOSED TO A 3rd PARTY WITHOUT WRITTEN PERMISSION OF CLIFF UK. © 1994

DRAWN: C.A.M.J.

APPROVED: R.W.T.

DRWG. No. **FCR14422** FORM: A4DRWGH