

ISS	AMEND	DATE
1	1st DRAWN	02/02/07

SECTION A-A

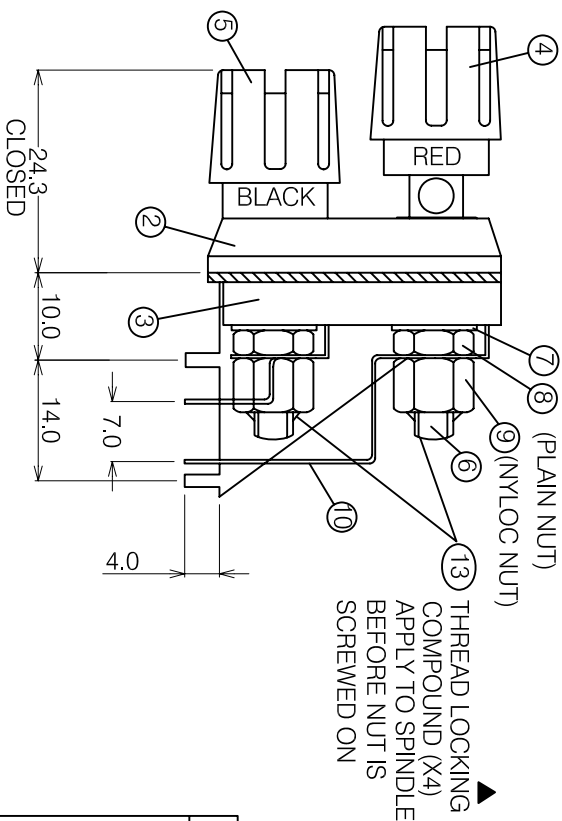

ITEM	P/No	QTY
1	CL7850	1
2	CL78521F	2
3	CL7854	2
4	CL7845R	2
5	CL7845B	2
6	CL7883F(1)	4
7	CL7880SA9	4
8	CL7880SA7	4
9	CL7880SA10	4
10	CL7855	2
11	CL7857	1
12	CL7856	1
13	THREAD LOCK COMPOUND	A/R

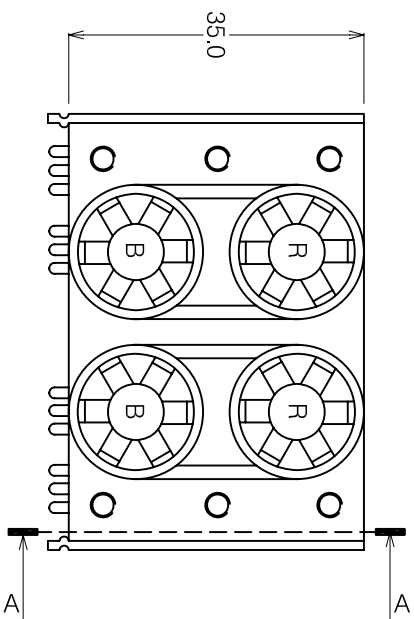
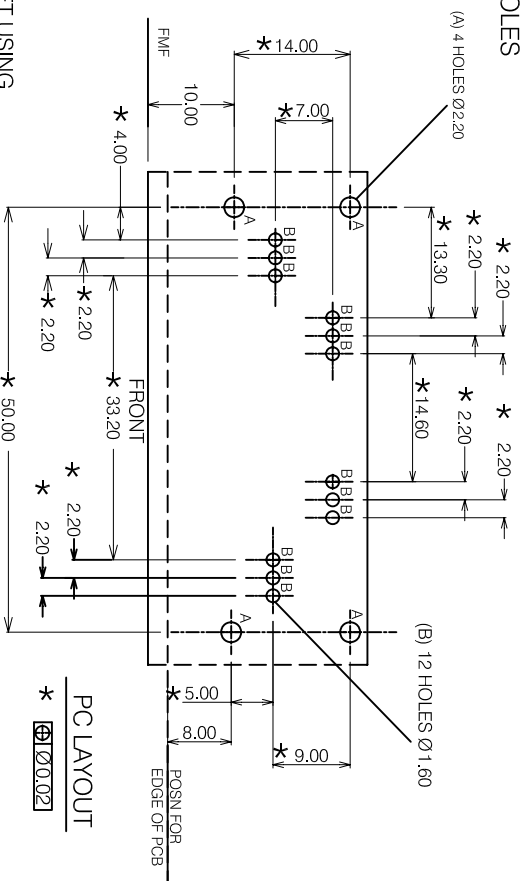
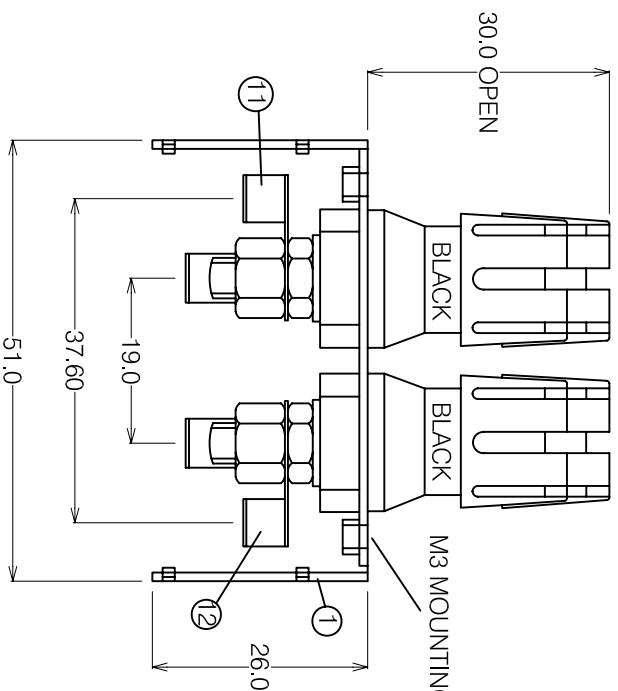

PC LEG POSITIONS TO BE SET USING A TEMPLATE WHILE NUTS ARE TORQUED

ALL NUTS TO BE TORQUED TO 1.5NM

ROHS COMPLIANT

Tolerance
 NO DEC. PLACE ±
 1 DEC. PLACE ±0.20
 2 DEC. PLACE ±0.05
 DIA. HOLES ±0.10
 ANGLES ±1/2°
 UNLESS OTHERWISE STATED
 WHERE USED F.R.

SCALE N.T.S.

CLIFF

MATERIAL: PARTS AS LISTED
 FINISH: CLEAN-NICKEL PLATED / TIN PLATED
 DRAWN: XHZ

TITLE: TERMINAL ASSEMBLY TPP3 / PCX-A / CT
 APPD: PCS
 DRWG NO: CL1597XA/T

FORM: A4DRWGH

DIMENSIONS IN MILLIMETERS UNLESS OTHERWISE STATED. WORK TO DIMENSIONS. DO NOT SCALE DRAWING. 3rd ANGLE PROJECTION. REMOVE BURRS. IF IN DOUBT ASK.